

**CMSC B240 Computer Organization - Spring 2025**  
**Lab Activity #3: Combinational Logic Circuits**

Student Name: \_\_\_\_\_

Student Name: \_\_\_\_\_

**Question #1**

Draw the circuit diagram for the logical expression:  
**(A and B) or (not C and not D)**

How many rows does the truth table for this circuit contain?

What is the output of this circuit when all inputs are 0?

**CMSC B240 Computer Organization - Spring 2025**  
**Lab Activity #3: Combinational Logic Circuits**

**Question #2**

Complete the truth table for the following circuit diagram:

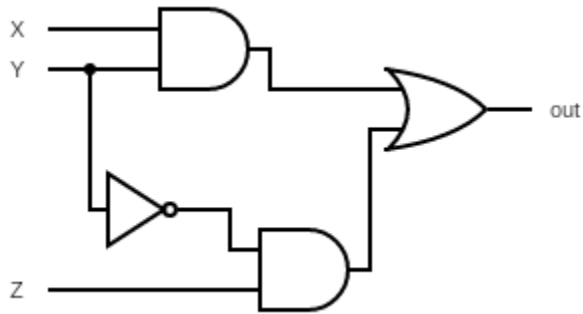

X	Y	Z	out
0	0	0	
0	0	1	
0	1	0	
0	1	1	
1	0	0	
1	0	1	
1	1	0	
1	1	1	

How many **transistors** does this circuit have?

CMSC B240 Computer Organization - Spring 2025

Lab Activity #3: Combinational Logic Circuits

**Question #3**

The following circuit is attempting to implement the logical expression **(A and B) or (not C)**:

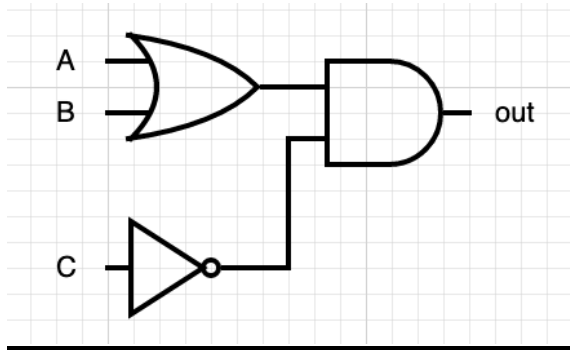

For what inputs does this circuit produce the **incorrect** output?

**Question #5**

Recall from our discussion of boolean logical operations that there was an “Exclusive-OR”, or XOR, function with the following truth table:

A	B	A xor B
0	0	0
0	1	1
1	0	1
1	1	0

That is, the output is 0 if the inputs are the same, and 1 if they are different. The XOR gate is represented with the following symbol:

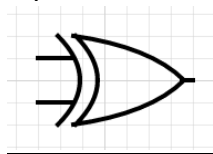

**CMSC B240 Computer Organization - Spring 2025**  
**Lab Activity #3: Combinational Logic Circuits**

Draw the circuit diagram for the logical expression  $(A \text{ xor } B) \text{ or } (B \text{ xor } C)$ , then complete the truth table on the next page.

A	B	C	$(A \text{ xor } B) \text{ or } (B \text{ xor } C)$
0	0	0	
0	0	1	
0	1	0	
0	1	1	
1	0	0	
1	0	1	
1	1	0	
1	1	1	

What do you notice about this truth table? That is, how could you briefly describe the operation that this circuit implements?

**CMSC B240 Computer Organization - Spring 2025**  
**Lab Activity #3: Combinational Logic Circuits**

**Question #6**

Consider the following circuit diagram:

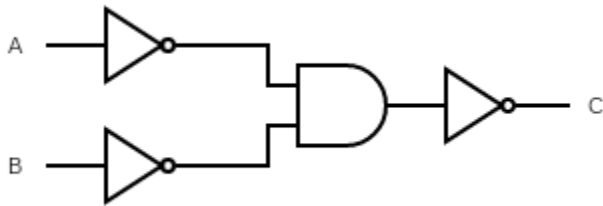

What is the logical expression for the output C in terms of the inputs A and B?

Complete the truth table for this circuit:

A	B	C
0	0	
0	1	
1	0	
1	1	

What other logical operation has the same truth table? *Hint! This is known as DeMorgan's Law!*

## CMSC B240 Computer Organization - Spring 2025

### Lab Activity #3: Combinational Logic Circuits

#### Question #7

Consider a circuit that has three inputs A, B, and C, and a single output, which should be equal to 1 if exactly two of the inputs are 1, but equal to 0 otherwise.

Complete the truth table for this circuit, then draw the circuit diagram.

A	B	C	out
0	0	0	
0	0	1	
0	1	0	
0	1	1	
1	0	0	
1	0	1	
1	1	0	
1	1	1	

## CMSC B240 Computer Organization - Spring 2025

### Lab Activity #3: Combinational Logic Circuits

#### Question #8

Design a circuit that converts an 8-bit 2's-complement binary number to its negation. The circuit should have eight input lines representing the number to be converted, and eight output lines representing the conversion.

For instance, if the eight input lines were 00110110 (representing +54) then the output lines should be 11001010 (representing -54).

Here are some hints!

- Think about the algorithm we use for converting a number to its negation, and then how you would implement that in a circuit.
- You can assume the existence of a 1-bit adder like we saw in class, and draw it as a box with three inputs (A, B, and  $C_{in}$ ) and two outputs (S and  $C_{out}$ ).
- Where needed, you can "hardcode" values such as 0 or 1 in the circuit.