

Logic Gates

CS 231
Dianna Xu

1

Claude Shannon

- Father of information theory
- His master thesis was the foundation of digital circuit design theory.

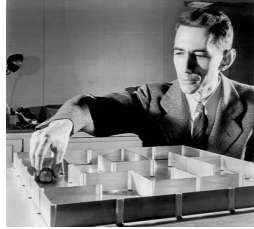

2

Circuits

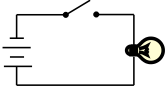
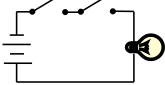
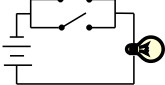
- Single switch 
- Switches in series 
- Switches in parallel 

3

Boolean algebra



- Boolean – a variable that is either true or false
- Boolean algebra – logical calculus of truth values
 - Very similar to Boolean logic
 - Variables can only be 1 or 0
 - Instead of true / false

4

Overview of Boolean algebra

- Not is a horizontal bar above the number
 - $\bar{0} = 1$
 - $\bar{1} = 0$
- Or is a plus
 - $0+0 = 0$
 - $0+1 = 1$
 - $1+0 = 1$
 - $1+1 = 1$
- And is multiplication
 - $0*0 = 0$
 - $0*1 = 0$
 - $1*0 = 0$
 - $1*1 = 1$

5

Overview of Boolean algebra

- Example: translate $(x+y+z)(\bar{x}\bar{y}\bar{z})$ to a Boolean logic expression
 - $(x \vee y \vee z) \wedge (\bar{x} \wedge \bar{y} \wedge \bar{z})$
- We can define a Boolean function:
 - $F(x,y) = (x+y)(\bar{x}\bar{y}) = (x \vee y) \wedge (\bar{x} \wedge \bar{y})$
- And then write a “truth table” for it:

x	y	F(x,y)
1	1	0
1	0	0
0	1	0
0	0	0

6

Basic logic gates

- Not $x \rightarrow \bar{x}$
- And $\begin{matrix} x \\ y \end{matrix} \rightarrow xy$ $\begin{matrix} x \\ y \\ z \end{matrix} \rightarrow xyz$
- Or $\begin{matrix} x \\ y \end{matrix} \rightarrow x+y$ $\begin{matrix} x \\ y \\ z \end{matrix} \rightarrow x+y+z$
- Nand $\begin{matrix} x \\ y \end{matrix} \rightarrow \overline{xy}$
- Nor $\begin{matrix} x \\ y \end{matrix} \rightarrow \overline{x+y}$
- Xor $\begin{matrix} x \\ y \end{matrix} \rightarrow x \oplus y$

7

Combinational circuit rules

- In general, gates can be combined into combinational circuits
- Rules:
 - Never combine two input wires
 - A single input wire can be split partway and used as input for two separate gates
 - An output wire can be used as input
 - No output of a gate can eventually feed back into that same gate

8

Converting between circuits and Boolean expressions

- Find the output of the following circuit

- Answer: $(x+y)y$
- Or $(x \vee y) \wedge y$

9

Converting between circuits and equations

- Find the output of the following circuit

- Answer: $\overline{\overline{x} \overline{y}}$
- Or $\sim(\sim x \wedge \sim y) \equiv xy$

10

Converting between circuits and equations

- Write the circuits for the following Boolean algebraic expressions

a) $\overline{x+y}$

11

Converting between circuits and equations

- Write the circuits for the following Boolean algebraic expressions

b) $\overline{(x+y)x}$

12

Writing xor using and/or/not

- $p \oplus q \equiv (p \vee q) \wedge \sim(p \wedge q)$
- $x \oplus y \equiv (x + y)(\overline{xy})$

x	y	$x \oplus y$
1	1	0
1	0	1
0	1	1
0	0	0

13

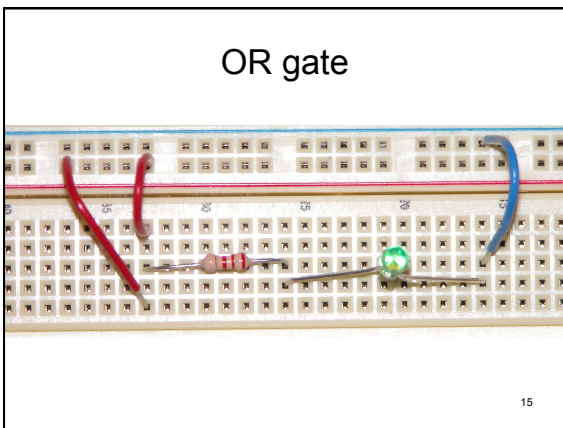
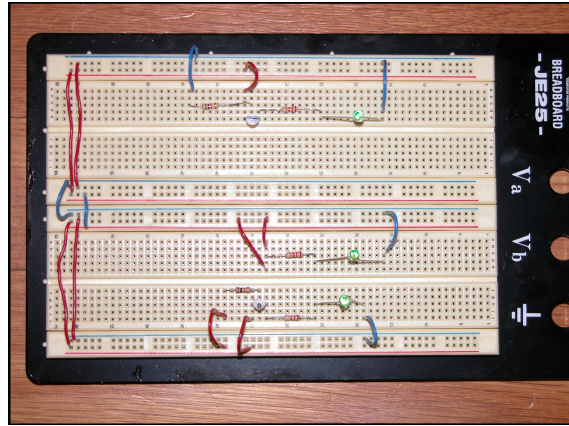

Integrated Circuits

- Very advanced (and miniaturized) electronic circuits
- Least expensive way to make logic gates in large volumes
- Mainly consist of semiconductor devices
 - Transistors – on/off/amplify
- Integrate a large number of transistors onto a tiny chip (die) ...

16

The 7400 chip, containing four NANDs.

17

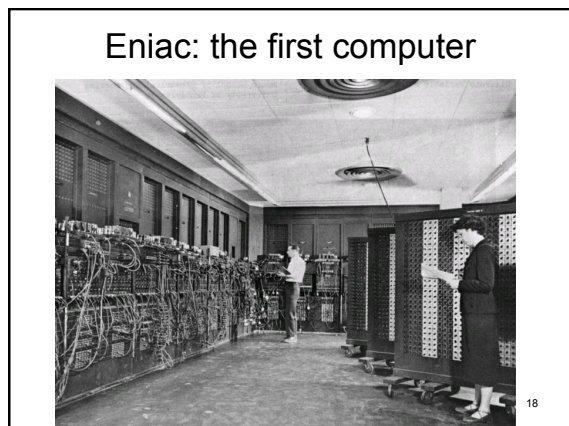

Eniac's vacuum tubes

A back panel of Eniac, showing the vacuum tubes

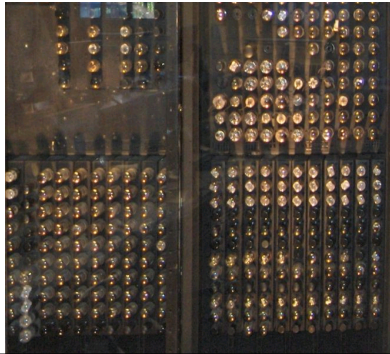

Integrated Circuits – Chips

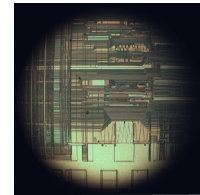
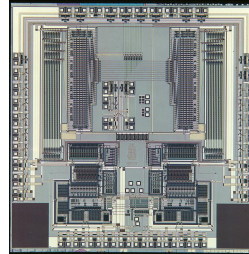

Upper interconnect layers on an Intel 80486 DX2 microprocessor die.

20

Moore's Law

- The complexity of an integrated circuit, with respect to minimum component cost, doubles every 18 months.
- True since the early 1970s
- Current leading developmental constraint?

21